

THE  
GRYPHON





# THE GRYPHON



## **Gryphon Diablo 333**

**Integrated amplifier**

**Owner's Manual**



## Table of Contents

Creating an Icon .....	7	Features .....	27
Gryphon's Founding Father .....	8	Specifications .....	28
Foundation for Excellence .....	8	Dimensions.....	29
Timeless Beauty, Aesthetic Perfection .....	11	Error Handling and Indication .....	30
Bespoke Manufacture		PS3 Phono Stage Module .....	31
for Heirloom Build Quality .....	11	Installation .....	31
The Gryphon Diablo 333 .....	12	Set-up menu .....	32
Placement .....	14	Rear Panel and Load Setting .....	33
AC voltage .....	14	Features and Specifications .....	34
Care and Maintenance .....	14	Phono wiring 1-2 .....	35
Choice of Cables .....	15	Phono wiring 3-4.....	36
Unpacking and Setup .....	16	DAC3 Digital to Analog Module .....	37
Burn-in and Warm-up .....	17	Installation .....	37
Main Switch .....	17	Burn-in and Warm-up .....	37
User Instructions .....	18	Selecting Digital Inputs .....	38
Menu Activated Functions .....	20	Settings .....	39
Rear Panel.....	23	Rear Panel .....	40
Remote Control.....	25	Features and Specifications .....	41
		Warranty & Support .....	42
		IMPORTANT SAFETY INSTRUCTIONS.....	43
		Notes .....	44



## The Gryphon Name

The Gryphon name and symbol are the ideal images for our brand,  
inspired by Greek mythology—part eagle, part lion—  
the perfect union of grace and agility with power and authority.

Gryphon Audio Designs is quite simply  
*“The ultimate choice for the enthusiast who wants the sound with no frills other than the  
luxury imparted by the fit, feel and finish.”*  
(Hi-Fi News & Record Review magazine, UK)

## The Gryphon Genetic Code

The Gryphon DNA has been defined by one writer as:

*“A code of perfectionism, the likes of which I’ve only ever seen at the Bugatti atelier in Alsace or at the great watch  
houses in Switzerland. It is the result of not accepting the notion of compromise, on any level.”*  
(Ken Kessler, audio critic)

At the very core of this genetic code lies what one critic described as Rasmussen’s  
*“Subversion of traditional hi-fi styling.”*  
(HiFi Choice magazine, UK)

with designs *“...so clean and simple, yet elaborate.”*  
(Positivefeedback.com, USA)

Similar sentiments echo around the world.

## Creating an Icon



In virtually every category of consumer goods—fashion, automobiles, furniture, wine, watches, etc.—there exists a revered top tier of luxury and excellence, a small yet celebrated, High End segment populated by innovative designers who pursue perfection with little concern for production economies, practicality or cost.

The essence of these “Aspirational Brands” is consistent: aesthetic beauty, advanced technologies, superior performance and extravagant build quality combine to achieve unsurpassed levels of fit, feel, finish and function; as a result, all of these offerings represent the very best that can be achieved, created for the discerning few who can appreciate and afford them.

While many of these marques are familiar, others are known only to a limited group of cognoscenti. Curiously, High End audio systems remain a mystery to many connoisseurs. This lack of awareness can be explained by products whose unimpressive aesthetics or awkward functionality clash with the refined sensibilities of potential owners.

At Gryphon, functionality has been optimized through intuitive user interfaces on high-visibility, multi-mode touch displays, with most functions repeated on dedicated remote handsets for optimum user-friendliness.

As for aesthetics, the sculptural beauty of Gryphon components, combined with their extraordinary fit and finish, elevates fine audio componentry to objects of worship which are right at home in the finest domestic spaces.

For the uninitiated, who mistakenly assume that they are unable to distinguish finer musical nuances as reproduced by High End audio systems, even the briefest audition proves that most individuals can discern and appreciate the “You-Are-There” realism offered by fine High End home entertainment equipment. Rest assured: if you’re passionate about music, the illusion that the listener can be transported to the performance venue is both apparent and addictive.

The fortunate few with the means to acquire the ultimate in-home entertainment experience owe it to themselves to experience the pleasure which a Gryphon Audio System delivers.



## Gryphon's Founding Father

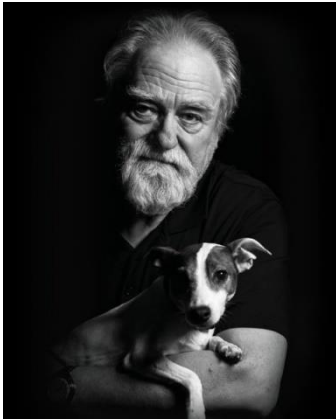

After 33 years at Gryphon Audio Designs, Flemming Erik Rasmussen recently retired from the company he founded in 1985 to devote himself to his favourite pastimes including his first love, painting.

Rasmussen's audio career was purely serendipitous, transitioning from fine arts to fabric design to High End Audio Distribution and finally, to the creation of The Gryphon brand as an expression of his audio philosophies. Gryphon's first product, the now legendary Gryphon Head Amp, was developed for Flemming's personal use. Almost immediately, demand generated by rave reviews and "Audiophile Buzz" led to the formal establishment of Gryphon Audio Designs.

Rasmussen's background in fine arts and industrial design has infused every Gryphon product with distinctive, luxuriant styling. His elegant, uniquely Scandinavian black-on-black designs defined the "Nordic Noir" aesthetic long before TV crime dramas appropriated the term. His legacy is palpable in the visual aesthetic of current Gryphon chassis, as well as the ethos of quality and performance embodied in all Gryphon products. His selection of Tom Moeller as Chief Electronics Designer set Gryphon on the path to the design and performance supremacy that it occupies to the present day.

Although Rasmussen's formal involvement with Gryphon ended with the chassis design of the Diablo 333, the principles upon which he founded the company continue to the present day and inspire every Gryphon Product.

## Foundation for Excellence: Gryphon Design Fundamentals

More than ever before, our commitment to absolute sonic and aesthetic perfection, regardless of price or commercial pressures, are the cornerstone of every Gryphon product. For more than twenty years, circuit design of all Gryphon Audio components has been overseen by Chief Electronics Designer Tom Moeller. The countless accolades, awards and critical acclaim that have distinguished Gryphon for nearly 40 years are the result of a commitment to excellence shared by every Gryphon employee.



## Great Performers Deserve Ultimate Performance

Thanks to state-of-the-art technical equipment and some of the finest minds in audio engineering, the Gryphon brand continues to define the highest standards of subjective and technical excellence. Common to all Gryphon components, these design fundamentals have proven essential for achieving ultimate audio realism/performance.

Utilized in every Gryphon product, our Dual Mono Signal Paths eliminate any possibility of crosstalk or other inter-channel interference and provides infinite channel separation, the result of which is unsurpassed ability to convey space, focus, depth and transparency. Spatial recreation, dimensionality and image focus are limited only by the information contained on the recording.

Because the electrical power in your home can fluctuate wildly in terms of voltage, noise and distortion, Gryphon incorporates Heavily Regulated Multi-stage Power Supplies that act as effective mains conditioning filters. Displays and control circuits are fed by independent power supplies to isolate any digital noise artifacts and effectively prevent extraneous noise from contaminating the analogue signal path.

While the printed circuit boards in most audio products utilize conductor traces a mere 35  $\mu\text{m}$  thick, Gryphon employs 70  $\mu\text{m}$  or Thicker PC traces of the highest purity copper. (The conductor traces developed for Apex are an astounding 105  $\mu\text{m}$  thick!)

Beginning with our very first product, “The Head Amp,” all Gryphon products have featured extremely Wide Frequency Bandwidth, because the ability to accurately reproduce infra-sonic and ultra-sonic frequencies ensures linear phase response across the audible frequency range, for superior tonality, detail resolution and spatial performance. The implementation of circuits with wideband frequency response is a painstaking, iterative endeavour in which physical component layout and grounding pattern of the circuit boards are crucial to the attainment of superior sonic performance with no loss of inherent electrical stability. Wideband frequency response ensures high slew rate—essential to the realistic recreation of the ultra-fast transients which routinely occur in live music—and is crucial in recreating the entire harmonic envelope of acoustic instruments.



All Gryphon designs are realized with none or an absolute minimum of negative feedback which, when present in large amounts, increases transient intermodulation distortion. With the exception of the Antileon series of power amplifiers (which utilize a minimum amount of

negative global feedback) all Gryphon amplifiers are designed with Zero Negative Global Feedback.

Gryphon's research into the detrimental effects of magnetically induced distorted (MID) has led to the Elimination of Magnetizable Materials wherever possible. To eliminate the effects of stray magnetic fields, non-magnetic materials are employed throughout every Gryphon product, with the unavoidable exception of the transformer shields.

The mechanical design and assembly methods of Gryphon chassis are carefully calculated to ensure Minimal Chassis Resonance, either through the use of high component mass, mechanical grounding or component decoupling. Vibration-sensitive parts, capacitors in particular, are thus guaranteed a non-resonant environment which, in turn, provides a solid foundation for optimal electrical performance.

Gryphon's Artistically Wrought, Massive Chassis offer a vibration-proof environment for the sensitive electronics inside and provide crucial shielding from a polluted world of low- and high-frequency radio waves, power-line radiation and other electrical interference. Our obsessive attention to such issues enables the relaxing, open and transparent Gryphon sound.

Unique, Non-intrusive Protection Circuitry offers reliable, fuss-free component protection without compromising signal purity or signal path simplicity. Ground paths have been carefully laid out in order to achieve superior sonic performance with no loss of stability. Component layouts are chosen to ensure the shortest conceivable signal paths.

In the interest of ultimate fidelity and signal purity, tone controls, balance controls and other superfluous circuitry have been banished from the signal paths of all Gryphon components.

Exhaustive investigation precedes the selection of every part and many Bespoke, Proprietary Components are custom-built exclusively for Gryphon. And because what is left out is just as important as what goes in, an absolute Minimum of Internal Wiring is utilized.

By devoting obsessive attention to each aspect of the circuit and fully understanding the purpose and behaviour of every single part of the whole, our designers can optimize performance in each section before moving on to the next step. This ensures simplicity, a short signal path and a unity of purpose towards a single, well-defined goal: musical purity.

## Timeless Beauty, Aesthetic Perfection

The pride of owning Ultra-Luxe audio systems should be apparent *before* the system is turned-on; for this reason, Gryphon products have always offered sculpturally beautiful design, exquisite control “Feel” and ultimate user-friendliness to complement their standards-setting audio performance. In every Gryphon product, form follows function in a unique synthesis of aesthetics and operational ease which proceed organically from the audio circuit design. Gryphon components combine cutting-edge technology and ageless industrial design executed with the best of artisanal handcraftsmanship, all in the service of music and to the delight of our fortunate owners. The peerless finish, build quality, ergonomics and pride of ownership that contribute to the Gryphon Product Concept can only be fully understood and appreciated through hands-on experience with our products.

High End audio systems don't exist in a vacuum: they reside in the finest domestic interiors outfitted with luxury accoutrements and decorated with a high sense of style. Gryphon produces aspirational components whose extraordinary performance is complemented by ravishing sculptural beauty. No expense has been—or every will be—spared in making every Gryphon component a source of pride of ownership, deserving of a place of honour in the finest homes.

## Bespoke Manufacture for Heirloom Build Quality

At our laboratories and manufacturing facilities in Denmark, we maintain full control over every aspect of development and production, and our team members follow each Gryphon component from initial concept, through early prototype, to final quality control. Printed circuit boards are assembled by a supplier of precision military and medical equipment employing the highest standards of quality control and pre-inspection of components and sub-assemblies. Chassis parts are manufactured by specialists chosen solely for their outstanding quality of workmanship. In every aspect of every Gryphon product, the same stringent standards of excellence apply. Each unit is individually tested and then, after a 48-hour burn-in sequence, each product again undergoes both electronic and audio performance testing, ensuring generations of flawless performance.

### **The System of a Lifetime**

Gryphon collectors will upgrade as new models become available: we welcome this and are grateful for their loyalty. On the other hand, there is a large and devoted group of music lovers who choose Gryphon because they consider their purchase to be a once-in-a-lifetime investment, because every component we make is Best-in-Class and because they rightfully



expect a lifetime of blissful, trouble-free operation. It is this mandate to deliver heirloom build quality that guides the development of every Gryphon component that has ever been made and that ever will be made. Generational Sustainability—the ability of a product to deliver musical pleasure for an unlimited lifespan—is a fundamental principle of Gryphon Product Development. The overwhelming majority of all Gryphon products are still in daily use. Just as the finest Swiss Watches and Exotic Cars are destined to be handed down from one generation to the next, every product that has ever carried the Gryphon name has been purpose-engineered to stand the test of time, to be cherished as a source of pride and passed along to one's fortunate heirs. In this, Gryphon is the antithesis of obsolescence and therefore unique in the world of consumer electronics.

Another distinction of the Gryphon Design Philosophy is that no component or circuit changes affecting the performance are made during the production run of any Gryphon product. (In those rare cases where a parts substitution is required, we change the model name as, for example, we introduced our Scorpio S CD Player when the DA-Converter ICs used in the original Scorpio was no longer available.) This unit-to-unit consistency is remarkable for consumer electronics products and is extremely difficult to achieve; however, it is the only way to assure long lifespan, long-term maintainability and high resale value.

### The Gryphon Diablo 333



Improving upon perfection and thereby surpassing the legendary Diablo 300 was no simple feat: introduced at High End Munich 2015, the Diablo 300 established a new benchmark in Integrated Amplifier performance. With unanimous praise from the High End press and thousands of units sold, Diablo 300 has maintained its “Best-in-Class” status for nearly a decade, repeatedly besting newer and more expensive competitors.

Over the past eight years, however, new component technologies and intensive engineering research have suggested areas for improvement. Circuit highlights from Gryphon’s flagship Power-, and Preamplifiers; the Apex and Commander, have “Trickled-Down” to the Diablo 333, which boasts ten percent more output power than its legendary predecessor. New ultra-fast, low-capacitance pre-driver transistors deliver both enhanced musicality and superior measured performance.

One look at the Diablo 333 and the Gryphon DNA is obvious: the triangular display panel with 4.3” TFT capacitive touch screen evokes the aesthetic created by Gryphon Founder Flemming

Rasmussen for Apex and Commander, as do custom-made chassis spikes which enhance both mechanical integrity and visual harmony. Also developed for Apex, Gryphon's bespoke binding posts are also found on the Diablo 333 rear panel. Sculpted from a block of aluminum, the remote handset in same style as the Commander handset complements the exquisite looks of the Diablo 333. An intuitive menu structure enhances the user interface while a USB 2.0 socket on the rear panel simplifies firmware updates.

The Diablo 333 can be outfitted with optional Phono Stage- and DAC modules which have been designed specifically for the Diablo 333 amplifier and future models.

The optional PS3 MM/MC Phono Stage module features True Dual Mono Class-A coupled topology from input to output. No global negative feedback and discrete balanced circuitry featuring matched transistor arrays. The balanced inputs features gold-plated Neutrik XLR input sockets. Moving Coil or Moving Magnet mode is set via the Diablo 333 menu. MC load impedance can be set externally on rear panel switches.

The optional DAC3 D/A module incorporate the latest High-Performance Sabre ES9039PRO DAC. Seven user-selectable PCM digital roll-off filters are included, as are a full assortment of USB, AES/EBU, S/PDIF and TOSLINK inputs. The DAC3 USB input is compatible with all current Digital Audio Formats.



## Placement

Do not place your Gryphon component on or near any source of heat such as power amplifiers. Do not place any object on the top covering the ventilation holes or heat sinks of your Gryphon component. Do not place it in an enclosed space such as a cabinet, unless ample ventilation is provided. Failure to observe guidelines may result in overheating.

## AC voltage

Your Gryphon unit is especially made for the AC voltage of the country to which it has been shipped. If the voltage of your Gryphon has been changed, the warranty is void and the product may be unsafe or malfunction. Correct AC polarity contributes greatly to optimum performance. If you are not using a three-pin, non-reversible power plug, please experiment with the orientation of the plug for optimum performance.

## Care and Maintenance

Gryphon products are handcrafted by individuals who take great pride in the high level of fit and finish which we achieve. To maintain your Gryphon components in pristine condition, please follow these simple instructions. Metal surfaces may be cleaned with a damp cloth or dry microfiber cloth. Some products made for treatment of vinyl interiors in cars may be useful. Test the product on a non-visible surface before using any fluids. Fingerprints may be removed with a damp cloth or dry microfiber cloth. In order to avoid damage to your Gryphon's finish, do NOT use spirits or paper tissue.

## Choice of Cables

Gryphon's basic philosophy is one of sonic neutrality. We prefer to leave interpretation to the musicians and singers. Therefore, you should not need a cable with a particular "sound" of its own to balance or "equalize" your system. Unfortunately, in some circles, cables have become an acceptable equalizer in the High-End audio industry.

Take the advice of your authorized Gryphon dealer in selecting interconnects and loudspeaker cables for your Gryphon equipment and for that matter power cords as well. After all, we are listening to current "converted" into music!

Naturally, Gryphon's own range of interconnects, loudspeaker cables and power cords are used in the development of Gryphon products. Gryphon cables are designed for ultimate neutrality and resolution. They are extremely revealing and will allow the ultimate quality of your Gryphon system or any fine audio components to come through clearly and undiminished.

All Gryphon amplifiers are designed and manufactured with an extreme bandwidth and in some cases the wrong choice of speaker cable can become an issue and will create potential problems in the collaboration between the amplifier and the speakers, with the speaker cable as an interactive factor. Gryphon recommends that no speaker cable on a Gryphon amplifier should be with a coaxial design, active shielding or special boxes that will add-on different types of filtrations. A speaker cable with a coaxial design or with active shielding will in most cases have a much lower bandwidth than the amplifier and therefore the amplifier will be met with a too high capacitive load and might cause oscillation of the amplifier. There is no need to actively add filtration on an analogue amplifier. It doesn't serve the final reproduction of the music any good.

Gryphon recommends using speaker cables with a low capacitance and a wide bandwidth in order to match the specs of the amplifier's bandwidth and output impedance. There is no need to add more "negative" filtration to the system as Gryphon is striving to have the finest level of tonal balance and neutrality. Choose your cables with the highest level of attention to the actual parameters of the cable design (e.g. cable geometry, capacitance, bandwidth, insulation, conductor material and connectors) and aim for low capacitance, low resistance and sonic neutrality.





## Unpacking and Setup

Please refer to separate Setup Instruction document included with your unit. You can also find this document on our website.

## SAFETY INSTRUCTIONS

**Hazardous live AC power! Please find important safety instructions on p. 43**



## Burn-in and Warm-up

Your Gryphon unit has been thoroughly tested and burned-in before shipping; however, performance will continue to improve during the first 40 – 50 hours of normal use. After this period, optimum performance will be reached approximately 45 minutes after turn-on.

## Mains Switch

The main ON/OFF switch on the Diablo 333 amplifier is located on the bottom panel of the unit, near the front. Engaging the power switch will illuminate the ON/STB (Standby) indicator on the Diablo 333 amplifier front display.

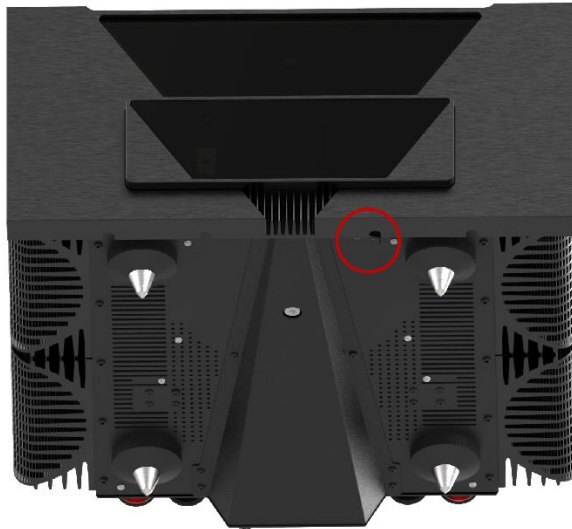

If the ON/STB (Standby) symbol flashes red continuously in STB mode; this indicates wrong / defective AC mains voltage. Please disconnect the Diablo 333 from AC power and contact your Authorized Gryphon Dealer or Distributor.

## User Instructions



### ON/STB touch Button:

Touch the ON/STB (Standby) symbol to turn the Diablo 333 ON or to engage Standby mode. When the amplifier is ON, the symbol turns green. (A red symbol indicates STB)

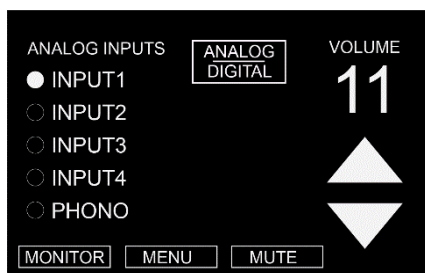
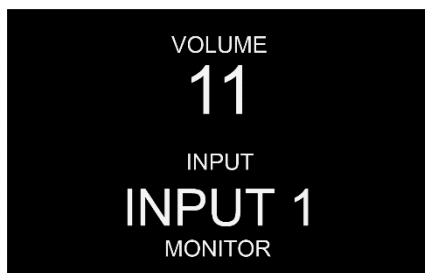

### Display View Modes:

The Gryphon Diablo 333 has two display view modes: “Simple View” and “Operation View”. After the start up sequence completes the Diablo 333 will enter “Simple View” mode. Immediately after touching the display area, the Diablo 333 display will enter “Operation View” mode. The Display will return to “Simple View” mode after 10 seconds if not being operated at the display panel. Setting can be altered in the menu.

### Simple View Mode:

In “Simple View” mode, the selected input and the volume level are displayed with a large font to make them easily readable from the listening position.

### Operation View Mode:

In “Operation View” mode, it is possible to operate the Diablo 333 via the touch display.

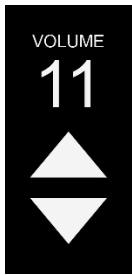

## VOLUME

The Diablo 333 amplifier uses a unique volume control. It is not a digital device, but a discrete solution based on fixed resistors in an ultra-short signal path involving a very small number of relays selected for perfect function and “sonic invisibility.” This technology can sometimes - depending on the material played - make a very small clicking noise when used. This is not a sign that anything is wrong and is normal.

Use the up/down arrows to adjust the volume for desired listening level. The minimum level is 0 and the default maximum level is 42. The start-up and maximum level can be set in the menu. See the description under “Menu Activated Functions”.

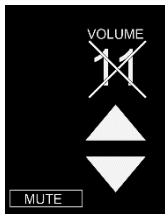

## MUTE

When the volume level is above 0, use this function to immediately mute the signal. Mute is indicated with a cross over the actual level.

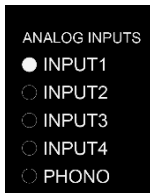

## INPUT SELECT

Use these touch buttons to select the desired input. Additional inputs (Phono, DAC) will be available when optional modules are installed.

The names for each input can be customized using the Menu. See the description under "Menu Activated Functions".



## MONITOR

Touch the MONITOR button to activate Tape Monitor. Tape Monitor is used to listen to a tape recorder, while the signal from the selected input is still present at the TAPE OUT output. If the recorder has a source/monitor function, this switch may be used to listen to the tape as it is being recorded. When selected, the display shows a filled MONITOR touch button. If an AV INPUT or INPUT4 is activated, the MONITOR function is not accessible. In these two cases the MONITOR touch button is hidden.



## MENU

Touch the MENU button to enter the Main Menu

## Menu Activated Functions

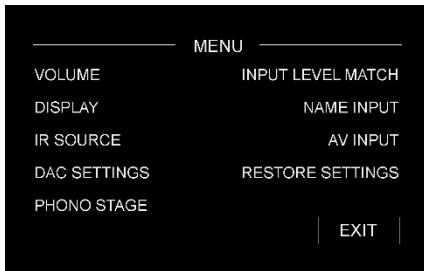

### MAIN MENU:

Select any of the menu items or press EXIT to leave the menu.

DAC SETTINGS and PHONO STAGE sub-menus available only with optional modules installed.

In the following section, each menu item will be described in detail:

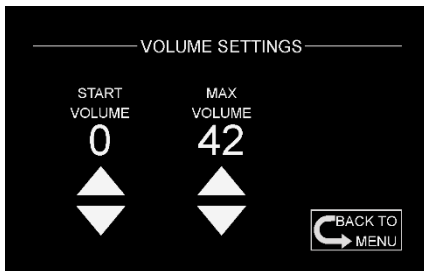

### START VOLUME:

Use the “Up” and “Down” arrows to adjust the desired start volume. The next time the Diablo 333 is powered up, the volume will be set to the value of Start Volume.

### MAX VOLUME:

Use the “Up” and “Down” arrows to adjust the desired Max Volume.

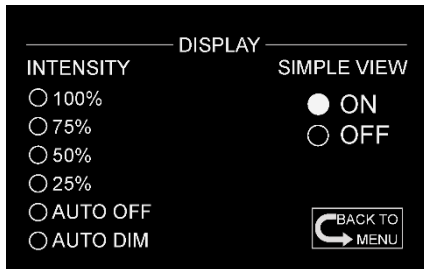

### DISPLAY:

Select fixed display intensity in four levels 25, 50, 75 or 100%.

Alternatively, select SIMPLE VIEW ON or OFF.

AUTO DIM: when the Diablo 333 display is in "Operation View" mode, the display intensity will be 100%. In "Simple View" mode, the display will be 100% when the Diablo 333 is operated from the remote control and after 20 seconds the intensity will lower to 25%, rendering the display unobtrusive and prolonging its lifespan.

AUTO OFF: when the Diablo 333 display is in "Operation View" mode, the display intensity will be 100%. In "Simple View" mode, the display will be 100% when the Diablo 333 is operated from the remote control and after 20 seconds the display will switch off. This will prolong the lifespan of the display. Any operation of the Diablo 333 will turn the display on again.

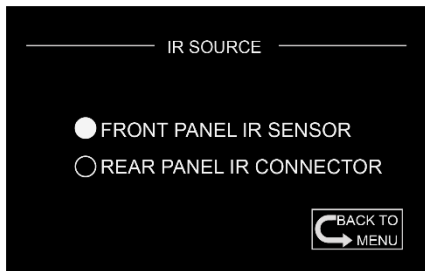

### IR SOURCE:

It is possible to connect an external active IR receiver to the rear panel of the Diablo 333. To use this option; select Rear Panel IR Connector.

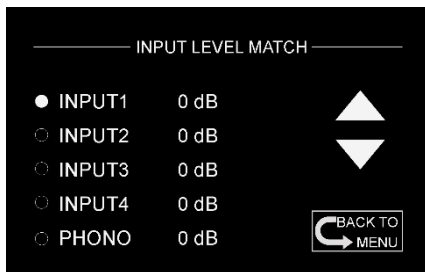

### INPUT LEVEL MATCH:

This option enables individually trimming the gain level of each input to maintain consistent volume when switching between sources.

Select the desired input and use the arrows up and down to adjust the level from 0 - +8dB.

Display showing optional Phono Stage installed.

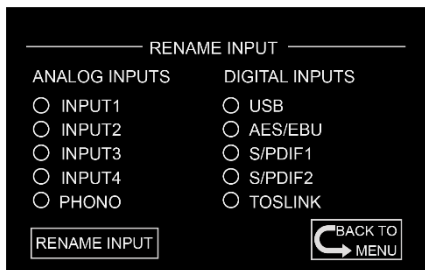

### NAME INPUT:

Select the desired input and press RENAME INPUT.

Use the QWERTY keyboard to enter the new input name and press OK to confirm. The input name can have a maximum of 8 characters.

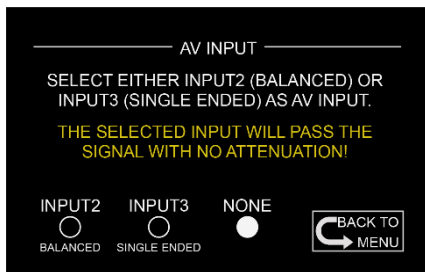
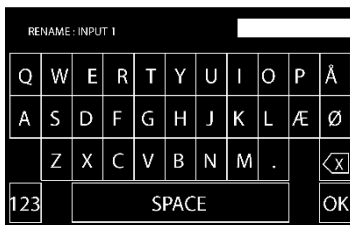

### AV INPUT:

This option allows you to use either Input 2 (balanced) or Input 3 (single-ended) on the Diablo 333 as a Power Amp input for a source (e.g. Home Theater Processors) with its own volume control. The signal from the selected input will be amplified with fixed gain (Default gain 30dB, + Input Level Match setting: 0 - +8dB). It is thus not possible to set the level with the volume control.

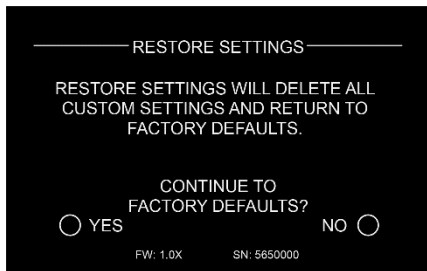

### RESTORE SETTINGS:

This option allows for resetting all settings to default, per below:

Start Volume: 0

Max Volume: 42

IR Source: Front Panel IR Sensor

Input Level Match: 0dB for all inputs

Input Names for Input 1-4: INPUT1-INPUT4

Input name for Phono input: PHONO

AV Input: None

Display mode: Auto Dim  
Simple View ON

MM/MC setting is not changed.

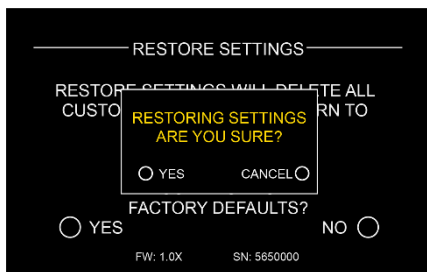

## Diablo 333 Rear Panel



### INPUT 1 - INPUT 2

Balanced XLR inputs to connect balanced sources.

### INPUT 3 - INPUT 4 (TAPE IN)

Single-ended RCA inputs to connect single-ended sources. INPUT 4 is also a dedicated "Tape Input".

### TAPE OUT

Single-ended RCA outputs which feed fixed level signal from the selected input source.

Please also see description of the MONITOR function for further information related to TAPE IN and TAPE OUT.

### SUB OUT

These single-ended RCA outputs allow you to connect an active subwoofer or a second power amplifier. The SUB OUT output is buffered using a high-grade Op-Amp. The signal is full range - no low pass filtering. Completely separated left and right channel signals.

## **USB**

The USB port is solely used for possible future Diablo 333 firmware updates.

Instructions how to perform a firmware update, will be conveyed if a firmware update is released.

## **IR**

The IR input enables connection of an external active IR receiver. One 3.5mm mini-jack labeled IR-INPUT is available for a stereo plug connection. The tip of the connected stereo mini-jack plug will be provided with +5VDC (max. 100mA). IR-signal on the middle ring and GND on the mini-jack sleeve.

## **GROUND**

Binding post for chassis ground.

## **Mains input sockets**

One IEC appliance C20 inlet (for power cords with IEC C19 receptacle)

AC FUSE holders and fuse values:

110-120Vac: T12.5A / 250V      220-240Vac: T8A / 250V

## **Balanced Connections**

All Gryphon products follow the AES standard for balanced connections:

1. Ground    2. Positive    3. Negative

Gryphon recommends the use of dedicated, balanced XLR interconnect cables.

Avoid the use of RCA-to-XLR adaptors as they will degrade system performance.





## Remote Control



### ON/STB

Places the Diablo 333 “ON” or in “STB” (Standby)

### MONITOR

Tape Monitor is used to listen to a tape recorder. If the recorder has a source/monitor function, this switch may be used to listen to the tape as it is being recorded. When selected, the display shows a filled white dot next to the MONITOR button.

### MUTE

When the volume level is above 0, use this function to immediately mute the signal. Mute is indicated on the display with a filled white dot and a cross over the actual level.

### DISPLAY

This remote button toggles through the different display intensity options. The selected option will show in the display. After 5 seconds, the display will return to normal.

### VOLUME Up and Down

Raises and lowers the Diablo 333 volume setting.

### INPUT Up and Down

Enables user to toggle between inputs.

### INPUT 1 – 4 and PHONO

The numbered buttons from 1 to 4 are used to directly selects the desired input. The PHONO button directly select the phono input from the optional PS3 Phono Stage module.

### DAC3 module, direct INPUT selection

If a DAC3 module is installed, the five digital input buttons are used to directly select the desired input: USB, AES/EBU, S/PDIF1, S/PDIF2 and TOSLINK.

### DAC3 module remote functions

FILTER button: toggles between the digital filters.

DSD LP button: toggles the DSD format analog low pass filter ON/OFF.

0/-6dB button: if -6dB is chosen, the output level from all digital inputs is lowered -6dB.

## Remote Codes

The Gryphon Diablo 333 amplifier remote control uses the Philips RC-5 standard for infrared communication.

The following RC-5, system 16 codes are used for the Gryphon Diablo 333 amplifier:

ON/STB .....	12	<b>Direct Analog Input Select</b>	
MUTE .....	13	INPUT 1 .....	1
VOL UP .....	16	INPUT 2 .....	2
VOL DOWN: .....	17	INPUT 3 .....	3
INPUT UP .....	32	INPUT 4 .....	4
INPUT DOWN.....	33	PHONO.....	5
MONITOR.....	21		
DISPLAY .....	15		
<b>DAC3 &amp; Digital Input codes</b>		USB .....	6
DAC3 FILTER.....	50	AES/EBU .....	7
DAC3 DSD LP .....	48	S/PDIF1 .....	8
DAC3 0/-6dB.....	36	S/PDIF2 .....	9
		TOSLINK.....	0

## Remote Control Battery

The remote control uses a single LR2450 / CR2450 coin cell battery.

Please replace the battery if the red indicator doesn't light up when pressing a button:

Carefully remove the screws holding the rear panel of the remote control using a 2mm hex socket screwdriver or Allen key.

Remove the rear panel and carefully slide the small battery drawer forward to release the battery.

Observe the orientation of the battery and replace with the new battery.



## Features



- True Dual Mono configuration.
- Zero global negative feedback.
- Microprocessor-controlled 43-step true balanced relay volume attenuator for best sonic performance featuring only 1-2 resistors in series with signal at all levels.
- Local Shunt regulators for best noise suppression.
- Ten high power output transistors each channel.
- Ultra-fast, low-capacitance pre-driver transistors.
- Polypropylene capacitors for local power supply decoupling.
- Optional PS3 MM/MC phono stage module.
- Optional DAC3 module with one USB, two S/PDIF, one AES/EBU and one optical input.
- Ultra-short signal path.
- Minimal internal wiring.
- Four-layer printed circuit boards with 70µ copper on all layers.
- Dual Mono Holmgren toroidal transformer.
- PCB-mounted sockets eliminate wiring and shorten signal path.
- Gold-plated Neutrik XLR sockets for two balanced sources.
- Gold-plated phono sockets with Teflon insulation for two inputs and two outputs.
- Gold-plated Gryphon custom-built binding posts.
- Fixed-level AV input for uncompromising integration with surround preamplifier.
- Input level match.
- 4.3" TFT capacitive touch screen with 4mm hardened glass in front.
- Intuitive menu structure.
- 12VDC link input and output.
- Infrared Receiver input via input on rear panel.
- Firmware upgradeable via USB 2.0 socket on rear panel.
- Non-invasive protection system.
- Infrared remote control.
- EU CE approval.
- Standby power consumption < 0.5W.
- Designed and built in Denmark.
- Exterior design by Flemming E. Rasmussen.
- Electronics design by Tom Møller.

## Specifications

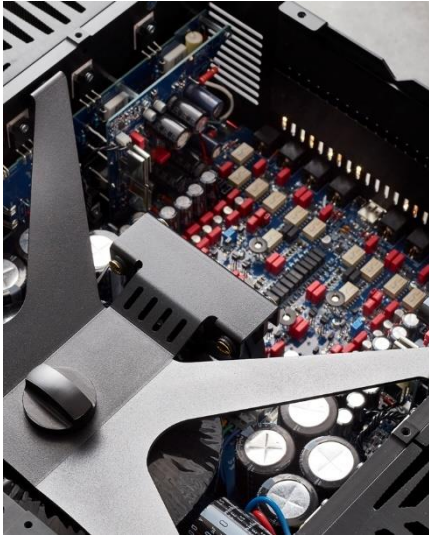

- 2x333W@8Ω, 2x666W@4Ω, 2x1100W@2Ω
  - Output impedance: 0,015Ω
  - Bandwidth (-3dB): 0,1Hz to 350 kHz
  - Power Supply Capacity: 2 x 68.000uF
  - Gain: +38dB
  - SUB output gain: +12dB
  - Input Impedance, balanced (20-20000Hz): 50KΩ
  - Input Impedance, single ended (20-20000Hz): 30KΩ
  - Power consumption: ≤ 0.5W (standby), approx. 180W (idle)
  - AC voltage range: 110-120V **OR** 220-240V – not changeable.
  - Operating ambient temperature range: 15 - 30°C / 59 - 86°F
  - MENU-controlled functions:
    - Volume Max Level
    - Volume Start Level
    - Display Intensity: (100%-75%-50%-25%, Auto Dim and Auto OFF)
    - Infrared source (Front or Rear Panel)
    - Input Level Match
    - Input Naming
    - Dedicate Input 2 (XLR) or Input 3 (RCA) to Volume-Bypass AV-input
    - Restore Settings
    - Phono Stage MM/MC selection (optional)
    - DAC level and filter settings (optional)
  - Outer dimensions, W x D x H: 468mm x 472mm x 245mm  
18.4in x 18.6in x 9.66in
  - Net weight: 50,6kg – 112lb
  - Shipping weight: 67,0kg – 148lb
- Please also see following page

Note: Specifications can be changed without notice.

## Dimensions, Diablo 333

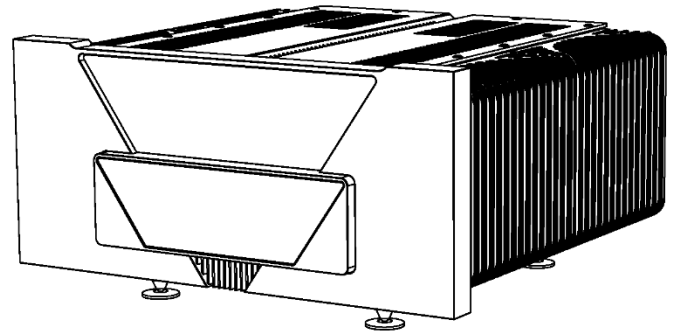
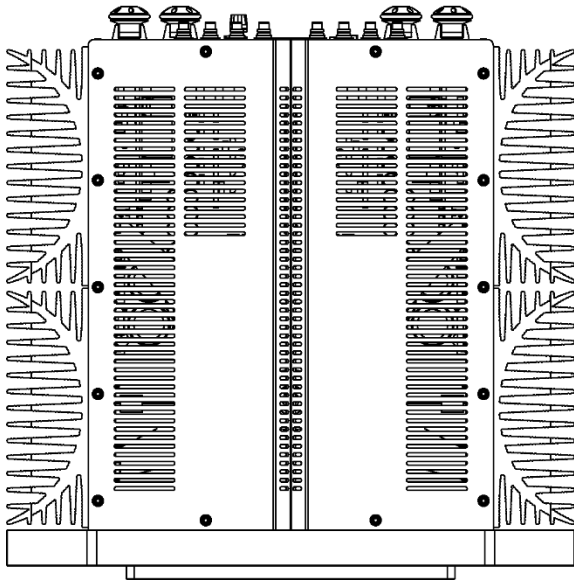
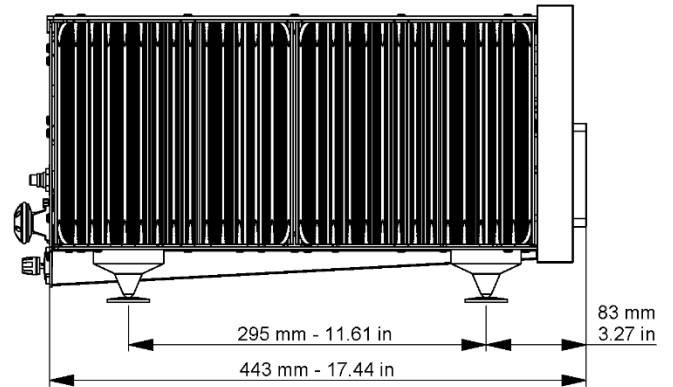
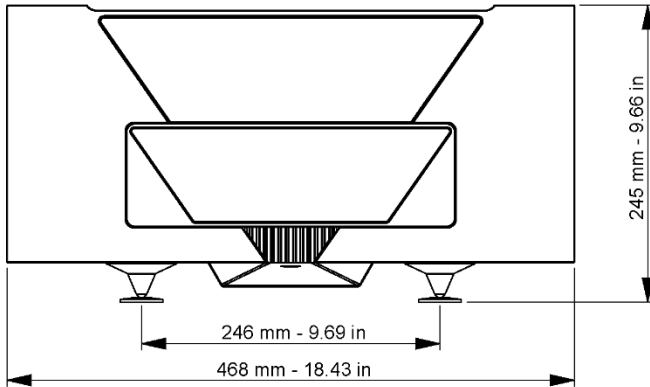

## Error Indication & Handling

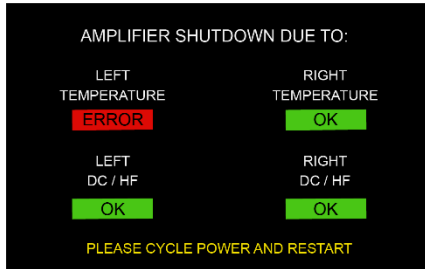

Two different error situations can be detected and indicated:

When excessive heat is detected in one or both channels, the Diablo 333 will mute, and the amplifier will go into stand-by mode. Normal operation can resume when the temperature is within safe operating limits.

If a DC/HF error is detected in one or both channels, the Diablo 333 will mute, and the amplifier will go into stand-by mode.

Next time the Diablo 333 is turned on after an error has occurred, the error indication display is shown. The error(s) which has been detected will be indicated with red background color.

The Diablo 333 analog amplifier stages are not turned on while this error indication display is shown.

The error indication display is shown until the Diablo 333 is turned off or brought into stand-by mode.

Next time the Diablo 333 is turned on, normal startup sequence is performed and if no error is detected during this sequence, the Diablo 333 is ready to use.

If an error(s) is persistent after two power cycles, please contact your local dealer for technical assistance.



## Optional PS3 Phono Stage Module



Gryphon Audio Designs has consistently supported the LP format with high performance phono stages. These optional modules are purpose-designed for installation in Gryphon preamplifiers and integrated amplifiers at all price points across our product range.

Based on the legendary Legato phono stage, the Gryphon PS3 MM/MC Phono Stage Module is a true balanced dual-mono design which offers enhanced channel separation, capable of extracting every musical detail for ultimate realism, and fully balanced signal handling from input to output.

The PS3 offers an extended range of MC cartridge impedance loading options accessible through the rear panel.

The PS3 module can be optionally added to the Diablo 333.

## PS3 Installation

Installation must be performed by authorized dealers or technicians only.

Unauthorized installation might void warranty.

### **SAFETY INSTRUCTIONS, Diablo 333**

**Hazardous live AC power! Please find important safety instructions on p. 43**

## Optional PS3 Phono Stage Module

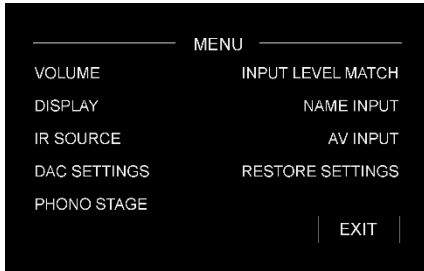

### SET-UP MENU

Select the PHONO STAGE sub-menu to select between MM (Moving Magnet) and MC (Moving Coil) mode.

Changing setting will alter the total gain through the PS3 module. During the change, internal electrical circuit needs to settle in, taking approximately 25 seconds. A progress bar will appear until this period is timed out and normal function can proceed.

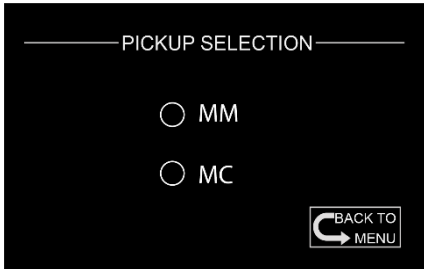

Please refer to Menu Activated Functions for Phono Stage Input Level Match and Input Naming.

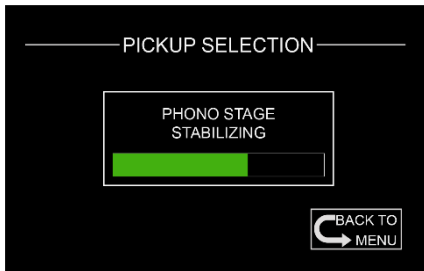



## Optional PS3 Phono Stage Module



### INPUT LEFT - INPUT RIGHT

Balanced XLR inputs to connect balanced phono cartridges.

*Avoid the use of RCA-to-XLR adaptors as they will degrade system performance.*

### MC (Moving Coil) Load setting switches no. 1-8

Set the desired MC load in both sides according to the table below.

Figure 1: Example 100  $\Omega$

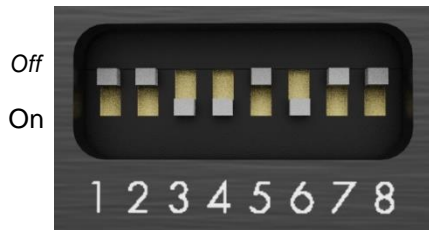
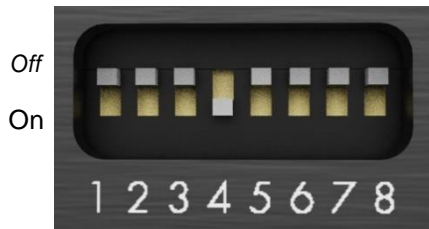

Figure 2: Example 300  $\Omega$



SW1	SW2	SW3	SW4	SW5	SW6	SW7	SW8	RLOAD $\Omega$
ON	ON	ON	ON	ON	ON	ON		20
ON		ON		ON		ON		30
ON								40
	ON	ON			ON	ON		50
	ON		ON		ON			60
		ON	ON	ON	ON	ON		85
		ON	ON		ON			100
		ON		ON		ON		120
		ON						150
			ON	ON				210
			ON					300
				ON				500
					ON			750
						ON		1000
								1600

## Optional PS3 Phono Stage Module

### Features:

- True Dual Mono Class A topology with no global negative feedback.
- Discrete build balanced topology.
- Designed to fully exploit the inherently balanced nature of the phono cartridge.
- MC load impedance can be set externally with rear panel switches.
- Changeable MM/MC setting via Gryphon Diablo 333 menu.
- Polypropylene capacitors used in RIAA correction stages.
- Matched Low Noise High Speed transistors in differential stages.
- DC-coupled topology from input to output
- Gold plated Neutrik XLR balanced input sockets.
- Ultra-short signal path with minimal internal/external wiring.
- Low noise +/- 23VDC regulated voltage supplies for excellent analogue THD and noise suppression.
- Four-layer printed circuit board with 70µm copper traces.
- Totally electrical and mechanical separated left and right channels for optimal channel separation.
- Designed and built in Denmark.

### Specifications:

- Gain: MC: 64dB  
MM: 42dB
- Impedance settings: MC: 20Ω to 1600Ω ref. to table.  
MM: 47KΩ // 220pF
- Signal to Noise ratio: MC: (Input 2.5 mV, 1 kHz): >72 dB  
MM: (Input 100 mV, 1 kHz): >84 dB
- Maximum input voltage: MC: Input 7mV,  
MM: input 100mV
- Net weight: 1.15kg – 2.5lb

**Note: Specifications can be changed without notice.**



**WARNING: Exceeding the maximum input voltage can lead to damage of the PS3 module**

## 1 Hardwiring (to solder terminals)

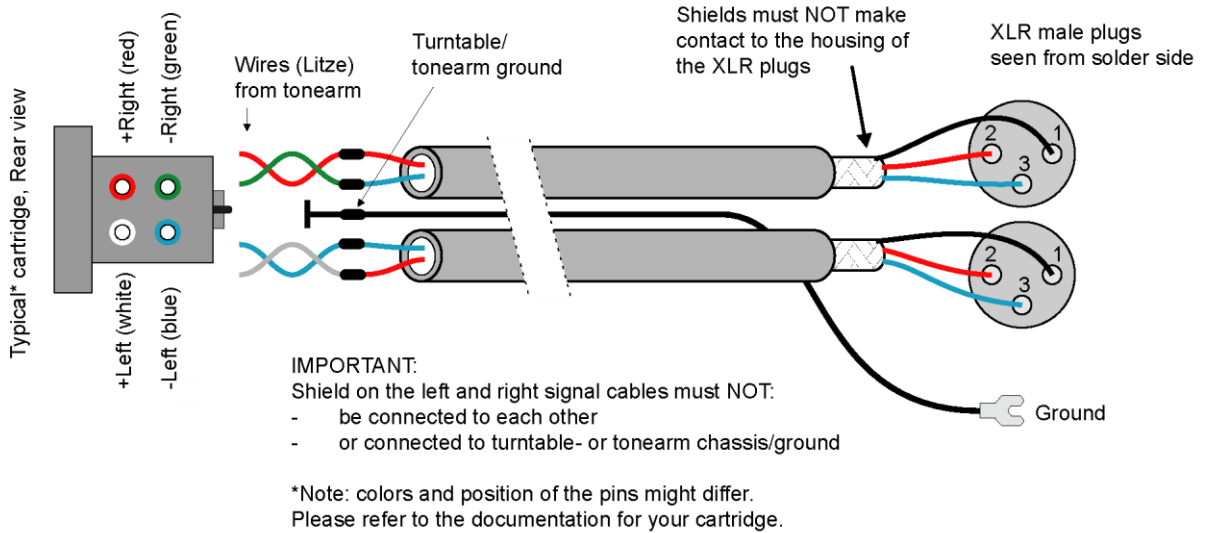

## 2 Wiring from SME 5-pin to XLR cables

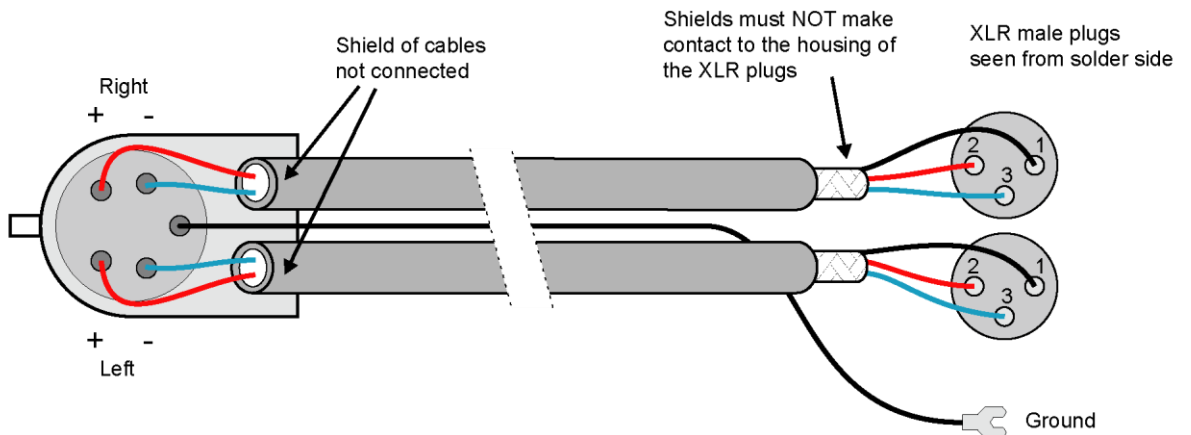

### 3 Wiring RCA to XLR cables

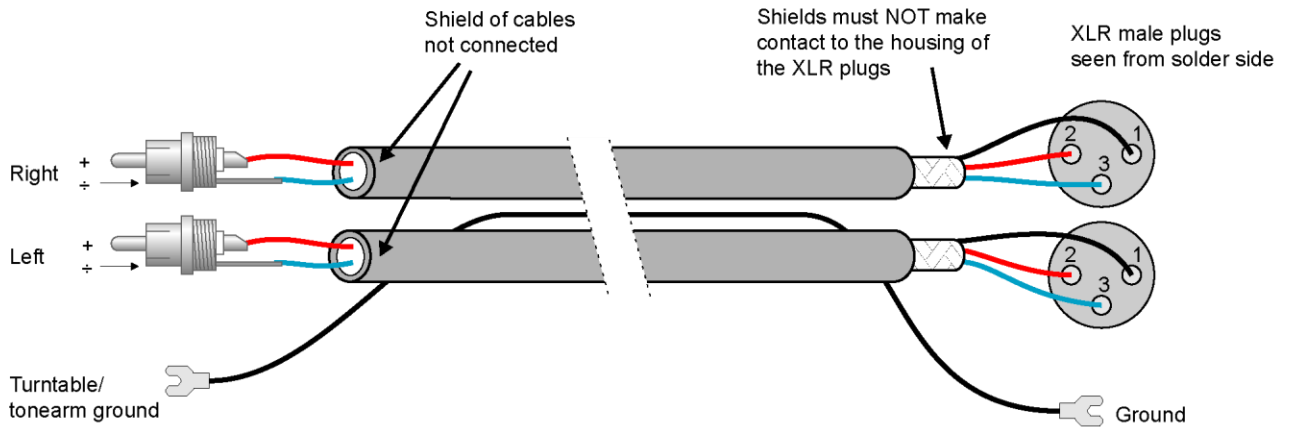

### 4 Wiring single ended to XLR cables

Please note that we strongly recommend to re-wire to balanced wiring as shown in the other examples.

Single-ended cabling prevents taking advantage of having both a balanced source and input.

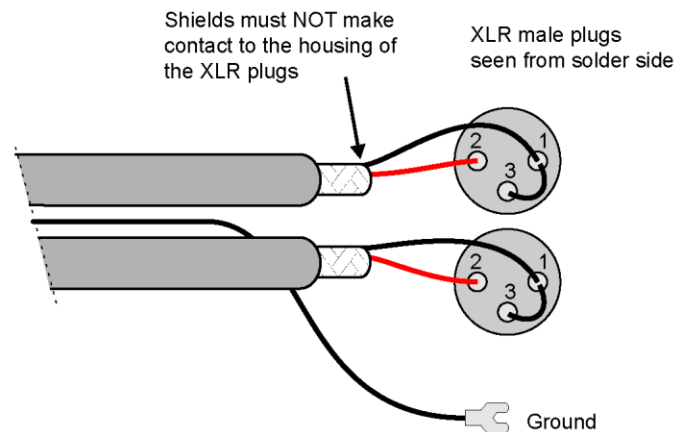

## Optional DAC3 module



The DAC3 is the perfect match for the new Diablo 333 integrated amplifier, adding five high performance digital inputs to the Diablo 333's existing four analog inputs and optional phono stage input.

Based on the newest ESS Technology Sabre flagship digital-to-analog converter, ES9039PRO it is capable of extracting every musical detail for ultimate realism.

The ES9039PRO has seven built-in pre-programmed digital filters which allows discerning users to tune the sound to their own personal taste.

Multiple local Ultra-low noise voltage supply stages together with discrete analog circuitry driven in full Class A, ensures the best possible sound performance.

With the DAC3 module built in, the Diablo 333 displays the chosen digital input Sampling frequency, PCM/DSD format and chosen digital filter setting.

The DAC3 is an updated version of our renowned DAC 300 module, offering an extended range of digital filter settings and next-level performance.

The DAC3 module can be optionally added to the Diablo 333 at any time, separate or together with the PS3 Phono Stage module.

## DAC3 Installation

Installation must be performed by authorized dealers or technicians only.

Unauthorized installation might void warranty.

**SAFETY INSTRUCTIONS, Diablo 333**  
**Hazardous live AC power! Please find important safety instructions on p. 43**

## Burn-in and Warm-up

Your Gryphon unit has been thoroughly tested and burned-in before shipping; however, performance will continue to improve during the first 40 – 50 hours of normal use. After this period, optimum performance will be reached approximately 45 minutes after turn-on.

## Optional DAC3 module

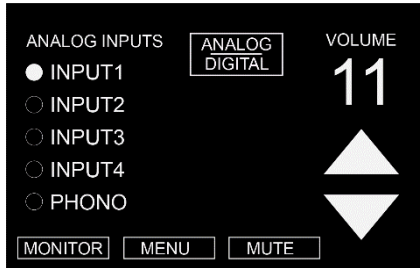

### SELECTING DIGITAL INPUTS:

Use the designated buttons on the remote control – or touch the display area to enter “Operation View” mode.

When in “Operation View” mode, touch the ANALOG/DIGITAL button to toggle between Analog- and Digital Inputs.

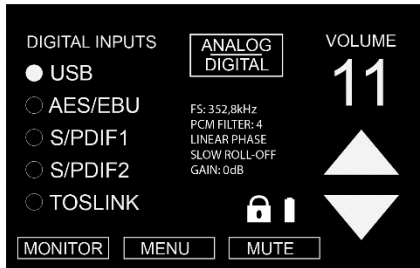

### DAC3 INPUT SELECTION AND DISPLAY INFORMATION:

Use the touch buttons to select the desired input: USB, AES/EBU, S/PDIF 1, S/PDIF 2, or TOSLINK.

The default names can be renamed in the NAME INPUT sub-menu.

The center section of the display provides information about the actual chosen digital input. The information shown depends on input choice and digital format:

**FS:** actual sample frequency of source material.

**PCM Digital filter** setting for PCM format only.

**DSD ANALOGUE LP ON/OFF:** Analogue Low Pass filter state for DSD format only.

**GAIN:** 0dB or –6dB output level of the DAC3 module.

**Padlock symbol:** DAC3 locked/unlocked to input signal.

**Battery charging / battery full symbol:** USB Super-Cap supply charging / fully charged.



## Optional DAC3 module

PCM FILTER: 4  
LINEAR FILTER  
SLOW ROLL OFF

### DAC3 SETTINGS:

The **PCM FILTER**, **DSD LP** filter and **0/-6dB** gain settings can be changed by the Diablo 333 remote control on the fly. When the display is in “Simple View” mode, the selected setting will show in large text on the display for 5 seconds. (PCM Filter / DSD LP Filter can be changed only when playing respectively PCM or DSD format).

See DAC PCM FILTER example to the left.

Select DAC SETTINGS sub-menu: to set the DAC3 settings without the Diablo 333 remote control.

MENU

VOLUME	INPUT LEVEL MATCH
DISPLAY	NAME INPUT
IR SOURCE	AV INPUT
DAC SETTINGS	RESTORE SETTINGS
PHONO STAGE	

EXIT

### PCM FILTER setting:

- 1: “MINIMUM PHASE”
- 2: “LINEAR PHASE APODIZING”
- 3: “LINEAR PHASE FAST ROLL-OFF”
- 4: “LINEAR PHASE SLOW ROLL-OFF” (default)
- 5: “MINIMUM PHASE FAST ROLL-OFF”
- 6: “MINIMUM PHASE SLOW ROLL-OFF”
- 7: “MINIMUM PHASE SLOW ROLL-OFF LOW DISPERSION”

DAC SETTINGS

PCM FILTER	DSD ANALOUGE: <input type="radio"/> ON
4	LOW PASS FILTER: <input checked="" type="radio"/> OFF
▲	GAIN: <input checked="" type="radio"/> 0dB
▼	<input type="radio"/> -6dB

LINEAR FILTER  
SLOW ROLL OFF

BACK TO MENU

**DSD ANALOUGE LOW PASS FILTER** setting: ON or OFF (default).

The DSD analogue LP filter, when set to ON, is active only when playing back DSD format.

**GAIN** setting: DAC output level (for all five digital inputs) 0dB (default) or -6dB.

## Optional DAC3 module inputs



- USB:** Connect to preferred Streamer, PC or MAC.  
Accepted USB formats and Sample Frequency:  
PCM (Pulse Code Modulated): FS up to and inclusive 384 kHz.  
DSD (Direct-Stream Digital): FS up to and inclusive DSD512.  
No drivers needed for MAC and Linux with UAC2 compliant kernel.  
DAC3 kernel/ASIO combined driver installation file can be downloaded at [www.gryphon-audio.com](http://www.gryphon-audio.com).
- AES/EBU:** Connect a digital source with balanced 110Ω output to this XLR input.
- S/PDIF 1-2:** Connect digital sources with single-ended 75Ω output to these BNC inputs.
- TOSLINK:** Connect a digital source with optical 2 channel output to this input.





## Optional DAC3 Features and Specifications

- True Dual Mono discrete build Class A Analog configuration.
- Zero global negative feedback.
- Sabre High-Performance ES9039PRO D/A converter.
- USB input compatible with following audio formats via PC/MAC/Linux:
  - PCM: 44.1, 48, 88.2, 96, 176.4, 192, 352.8 and 384 kHz, up to 32 bits.
  - DSD via USB: DSD64, DSD128, DSD256 and DSD512.
- AES/EBU and S/PDIF inputs compatible with PCM: 22.05, 24, 32, 44.1, 48, 64, 88.2, 96, 176.4 and 192 kHz, up to 32 bits.
- TOSLINK input compatible with PCM: 22.05, 24, 32, 44.1, 48, 64, 88.2, 96 kHz, up to 24 bits.
- Seven user-selectable PCM digital roll-off filters.
- Temperature-compensated, ultra-low jitter crystal oscillator with better than 5 parts per million accuracy.
- Super-Capacitor (12.5 Farad!) power supply for USB module - acts like a true battery supply.
- First-order PCM analogue filters and second-order DSD analogue filters with Polypropylene capacitors.
- Analogue output stages with ultra-low noise +/- 22VDC regulated voltage supplies for best analogue THD and noise suppression.
- Multiple Local Voltage regulators for best digital noise suppression.
- Separate left/right channel ultra-low noise power supply for analogue section of ES9039PRO DAC.
- Ultra-short signal path.
- Minimal internal wiring.
- Six-layer printed circuit boards.
- PCB-mounted input sockets eliminate wiring and shorten signal path.
- Gold-plated Neutrik XLR socket for one balanced 110Ω AES source.
- Gold-plated 75Ω BNC sockets with Teflon insulation for 2 S/PDIF sources.
- One TOSLINK optical fiber input.
- Designed and built in Denmark.

Note: Features and specifications can be changed without notice.

## Warranty & Support

The Gryphon Diablo 333 amplifier is warranted against failures arising through faulty workmanship and materials for a period of 3 years from date of purchase. The warranty is not transferable.

This warranty is only valid in the country where the product was purchased.

All claims under this warranty must be made to the distributor in the buyers' country by returning the unit securely packed in the original box with all accessories, postage/freight prepaid and insured. The unit will be repaired or replaced at no charge for parts and labor.

This warranty will be void if the serial number of the unit has been defaced or removed.

No user serviceable parts inside. This warranty will be void if the unit has been repaired or modified by non-authorized Gryphon dealers or distributors. Optional modules must be installed by authorized dealers and distributors only.

This warranty does not cover damage due to misuse, accident or neglect.

This warranty is not valid if the operation voltage of the product has been changed.

The distributor or manufacturer, Gryphon Audio Designs, Denmark, retains the exclusive right to make such judgement on the basis of inspection.

The retailer, distributor or manufacturer of the Gryphon shall not be liable for consequential damage arising from the use, misuse or failure of this product, including injuries to persons or property.

Please do not directly contact Gryphon for repair, warranty issues or technical questions. Our local representatives are competent and happy to help you.

To qualify for this warranty; you must register your purchase online at [gryphon-audio.com](http://gryphon-audio.com).

Notes	
Gryphon Model:	
Serial No.:	
Date of Purchase:	
Dealer:	
Country:	

## IMPORTANT SAFETY INSTRUCTIONS

Read these instructions.

Keep these instructions.

Heed all warnings.

Follow all instructions.

Do not use this apparatus near water.

Clean only with a damp or dry cloth.

Do not block any ventilation openings. Install in accordance with the manufacturer's instructions.

Do not install near any heat sources such as radiators, heat registers, stoves, or other apparatus (including amplifiers) that produce heat.

Do not defeat the safety purpose of the polarized or grounding-type plug.

US power plugs (NEMA5-15) only: A polarized plug has two blades with one wider than the other. A grounding type plug has two blades and a third grounding prong. The wide blade or the third prong is provided for your safety. If the provided plug does not fit into your outlet, consult an electrician for replacement of the obsolete outlet.

Protect the power cord from being walked on or pinched particularly at plugs, convenience receptacles, and the point where they exit from the apparatus.

Only use attachments/accessories specified by the manufacturer.

Unplug this apparatus during lightning storms or when unused for long periods of time.

Refer all servicing to qualified service personnel. Servicing is required when the apparatus has been damaged in any way, liquid has been spilled or objects have fallen into the apparatus, the apparatus has been exposed to rain or moisture, does not operate normally, or has been dropped.

Do not open the equipment to reduce the risk of electrical shock. Refer all disassembling to qualified service personnel.

**WARNING:** To reduce the risk of fire or electric shock, this apparatus should not be exposed to rain or moisture and objects filled with liquids, such as vases, should not be placed on this apparatus.

To completely disconnect this equipment from the mains, disconnect the power supply cord plugs from the receptacle.

The mains plug of the power supply cords shall remain readily operable.

No naked flame sources, such as lighted candles, should be placed on the apparatus.

There are multiple internal fuses in the Diablo 333 amplifier. Fuse values are printed on the circuit board.

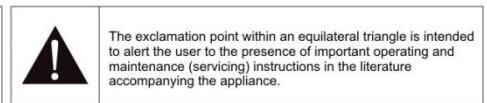
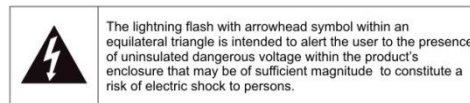

## Remote Control Battery

### WARNING

#### Danger of explosion

Danger of explosion if battery is incorrectly replaced.

Replace only with the same or equivalent type.

### WARNING

#### Chemical burn hazard

If the coin/button cell battery is swallowed, it can cause severe internal burns in just 2 hours and can lead to death.

If you think batteries might have been swallowed or placed inside any part of the body, seek immediate medical attention.

## Notes

---

---

---

---

---

---

---

---

---

---

---

---

---

---

---

---

---

---

---

---

---

---

---

---

---

---

---

---